

BUTEE COMMANDE NUMERIQUE HG1 POUR PRESSE PLIEUSE

COURSE 490mm
+ SUPPORT 1/2/3
VITESSE AXE X: 200mm/s

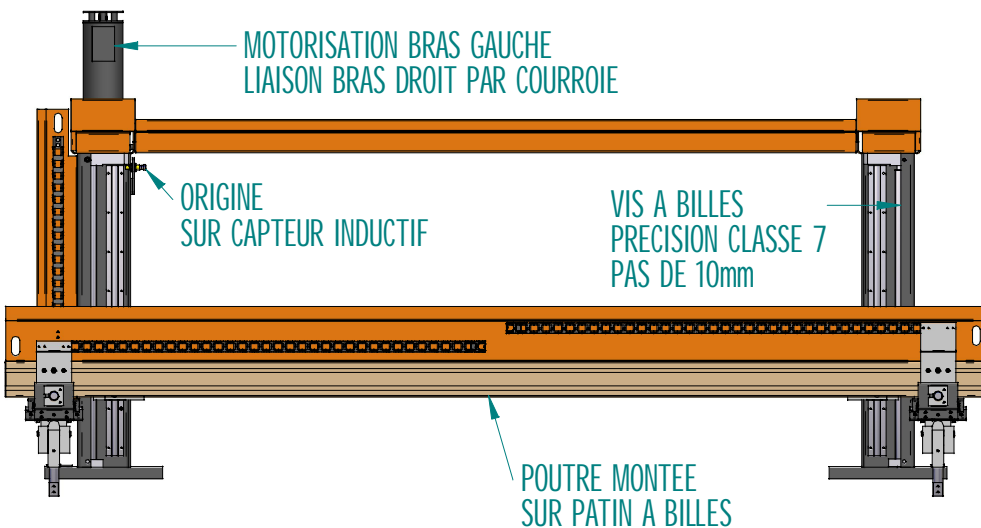

3 MISES EN BUTEES SUPPLEMENTAIRES
+35mm
+60mm
+100mm

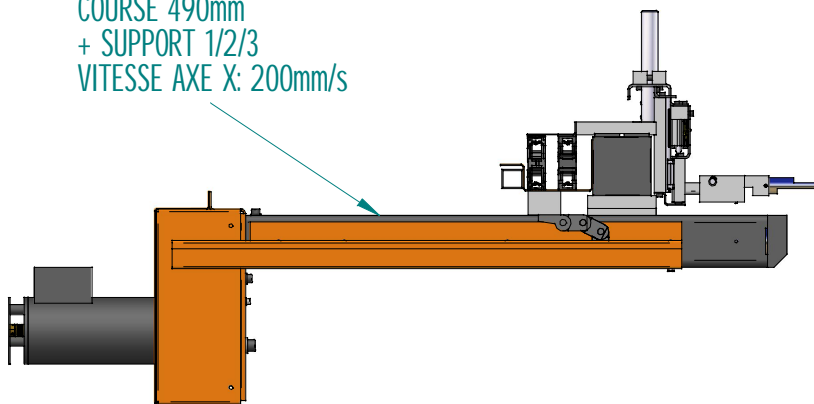
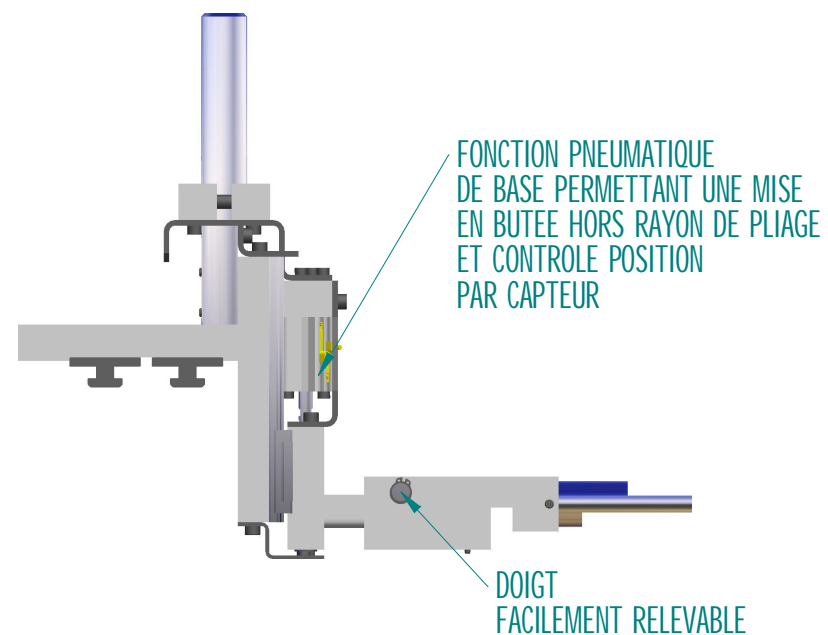
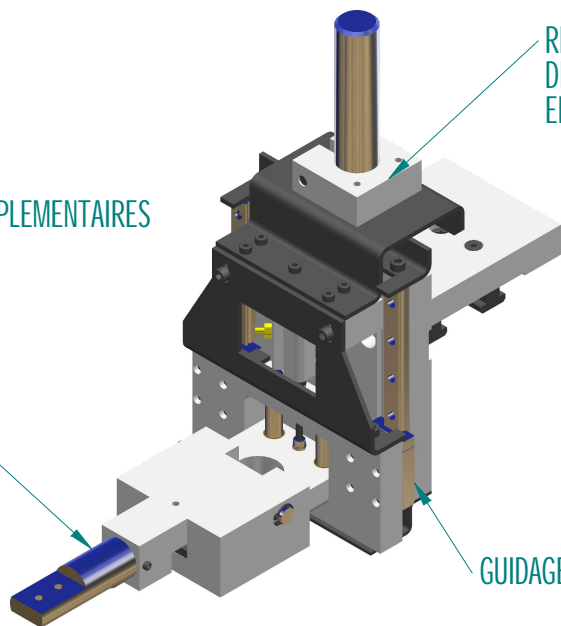

MACHINES
MB
S
P
I
E
R
I
E

ZA-Rue de la citadelle
85150 St Georges de pointindoux
Tél: 02 51 34 07 94 - Fax 02 51 34 07 58
Email: lablanchard@mbtolerie.com